

THIS DOCUMENT IS THE PROPERTY OF AIRO INDUSTRIES,CO AND IS PROVIDED ON THE EXPRESSED CONDITION THAT IT IS NOT TO BE DISCLOSED REPRODUCED IN WHOLE OR IN PART, OR USED FOR MANUFACTURE BY ANYONE OTHER THAN AIRO INDUSTRIES WITHOUT ITS WRITTEN CONSENT. AND THAT NO RIGHTS PERMITTED TO DISCLOSED OR SO USE ANY INFORMATION CONTAINED IN THIS DOCUMENT

REVISION			
LTR	E.O. NO.	DATE	APPD
N/C	NEW RELEASE	04/14/2009	

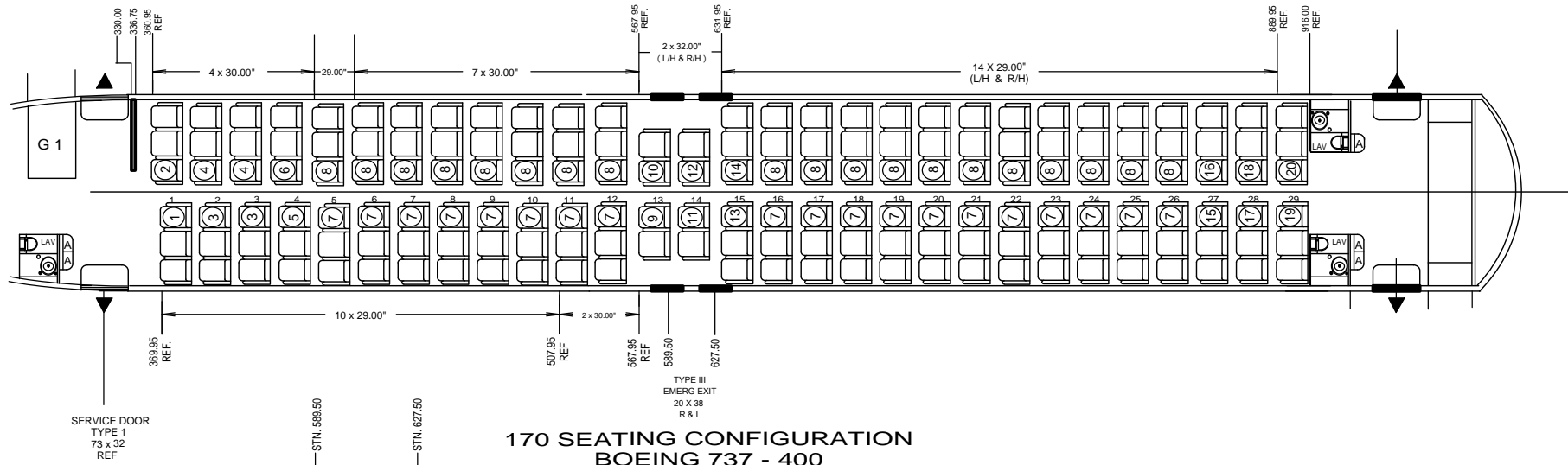

170 SEATING CONFIGURATION
BOEING 737 - 400

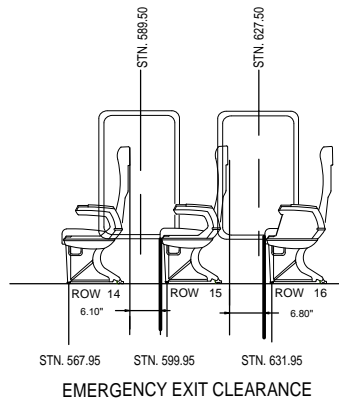

EMERGENCY EXIT CLEARANCE

- 12 - GENERAL NOTE 2 THRU 9 ARE THE INSTALLERS RESPONSIBILITY TO INSURE COMPLIANCE WITH APPLICABLE FAR REQUIREMENTS.
- 11 - SEATS ASSEMBLIES ITEM NUMBERS 9-14 MANUFACTURED BY WEBER , ALL OTHER SEAT ASSEMBLIES MANUFACTURED BY FAIRCHILD BURNS
- 10 - SEAT LOCATION MEASURED FROM CENTER LINE OF FORWARD SEAT STUD AT INBOARD SEAT TRACK.
- 9 - SEAT BACK BREAKOVER - MIN. 25 LBS FORCE APPLIED IN HORIZONTAL DIRECTION.
- 8 - ALL SEATS CUSHION NEED TO BE MARKED AS FIRE BLOCKED OR FLAMMABILITY COMPLIANCE PER 25.853 OTHERWISE Q.C. IS TO GATHER THIS DATA FOR THE FILES
- 7 - VERIFY THAT ALL FOOD TRAYS CAN BE LOCKED IN UP / STOWED POSITION.
- 6 - VERIFY FASTEN SEAT BELT SIGNS ARE INSTALLED VISIBLE TO ALL PASSENGER.
- 5 - VERIFY DECALS FOR LIFE VEST UNDERNEATH SEATS.
- 4 - ALL PASSENGER SEATS MUST MEET REQUIREMENTS OF TSO C - 39a
- 3 - ALL PASSENGER, FLIGHT ATTENDANT, AND OBSERVERS SEATS SHALL BE FIRE BLOCKED I. A. W. FAR 26.853
- 2 - ALL LAP BELTS MUST MEET REQUIREMENTS OF TSO C - 22
- 1 - INSTALL SEATS I. A. W. AMM

NOTE:

1	886568-304	R/H TRIPLE NRW, NO RCLN, NO BREAKOVER, H/CAP	20
1	886568-303	L/H TRIPLE NRW, NO RCLN, NO BREAKOVER, H/CAP	19
1	886568-302	L/H TRIPLE NRW, H/CAP	18
1	886568-301	L/H TRIPLE NRW, H/CAP	17
1	886567-304	R/H TRIPLE NRW, LEG I/B OFFSET	16
1	886567-303	L/H TRIPLE NRW, LEG I/B OFFSET	15
1	834685-444/MOD	R/H TRIPLE IAT NO, O/B ARMREST, NO BREAKOVER	14
1	834685-443/MOD	L/H TRIPLE IAT, NO O/B ARMREST, NO BREAKOVER	13
1	834685-442	R/H DBL STD, NO RCLN, NO BREAKOVER	12
1	834685-441	L/H DBL STD, NO RCLN, NO BREAKOVER	11
1	834683-416/MOD	R/H DBL STD, NO RCLN	10
1	834683-415/MOD	L/H DBL STD, NO RCLN	9
19	886566-302	R/H STD TRIPLE	8
19	886566-301	L/H STD TRIPLE	7
1	886566-304	R/H TRIPLE STD W/TRACKADAPTER	6
1	886566-303	L/H TRIPLE STD W/TRACK ADAPTER	5
2	886567-302	R/H TRIPLE O/B NRW	4
2	886567-301	L/H TRIPLE O/B NRW	3
1	886565-302	R/H TRIPLE NRW, IAT, NO B/O, LEG I/B OFFSET	2
1	886565-301	L/H TRIPLE NRW, IAT, NO B/O, LEG I/B OFFSET	1

REQ,D	PART NO.	NOMENCLATURE	ITEM
UNLESS OTHERWISE SPECIFIED DIMENSIONS ARE IN INCHES .xx = +/- .030 .xxx = +/- .010 ANGLES = +/- 1/2	DRAWN ROSS SALEM	DATE 04/14/2009	AIRO INDUSTRIES, CO 527 JESSIE STREET SAN FERNANDO, CA 91340 INTERIOR ARRANGEMENT 170 PAX B737
	CHECK	DATE 04/14/2009	
	ENGRG	DATE 04/14/2009	
	MFG ENGRG	DATE 04/14/2009	
BREAK ALL SHARP EDGES MARK PART PER ML-STD-130	CONFIG, CNTL	DATE 04/14/2009	SIZE A
	IN LIEU OF	DATE 04/14/2009	
MACHINED SURFACE FINISHES 126 MAX.		DWG NO. 2010-8999	REV. N/C
SCALE NONE		SHEET 1 OF 1	